



aliyaqoob.com

EMICO
WHEATON
by Gardner Denver

Aviation solution



Aviation Fuel Transfer Equipment

Aviation fuel transfer equipment is the first choice for safe and spillage free bunkering of aviation fuels.

Used in commercial, offshore and military applications. TODO aviation fuel transfer couplings are built to take the strains of rapid fuelling activities in the most demanding of applications.

Based on proven TODO-MATIC® coupling designs, TODO aviation fuel transfer couplings offer high flow fuel delivery without the cost and complexity normally associated with ISO45 connections.

EMCO WHEATON DRY-BREAK and TODO-MATIC DRY-BREAK couplers provides easy connection, and a reliable means of transferring aviation fuels without spillage.

Features

- Economical alternative to ISO 45 standard hose couplers.
- Valves open and close automatically on connection and disconnection.
- Simple single action operation, no levers or switches to operate.
- Valves are guaranteed closed prior to disconnection.
- Minimal residual loss on disconnection.
- Will connect and disconnect under pressure and flow where necessary.
- Extremely reliable, very few moving parts.
- Robust construction, no external operational components.

Technical Data

TODO-45 Dry Break

Sizes: 2½" (DN65)

Materials: Body: Aluminium
Coupling ring: Gunmetal
Inner parts: Aluminium and stainless steel

Seals: FKM (Viton®), Fluorosilicone. Other materials on request

Working pressure: PN10

Test pressure: PN15

End connections: BSP- and NPT-threads. DIN-, ASA-, TW- and TTMA-flanges (available for the tank unit). Other threads and flanges on request.

Compatibility: ISO 45, MS24484, STANAG 3105, British Areospace Spec. 2C14.

Viton® is a registered trademarks of DuPont Performance Elastomers.

Certificates / approvals

- VdTÜV type approval, mark TÜ.AGG.162-93 towards ADR, RID, IMDG and VDI-rules 2440, part 3.3.1.3.
- CE-marked, European directives 97/23/EC (PED) and 94/9/ EC (ATEX) compliant.
- TDT approval, mark TDT-UW-30/09 towards ADR/RID in Poland.
- Manufactured under EN ISO 9001:2000.
- Certified towards ISO 14001:2004 and OHSAS 18001:2007.
- Manufactured towards EN 13480 and EN 13445.

Emco Wheaton's military-standard aviation fuel transfer equipment is made for the most demanding applications. Trusted by commercial and military bodies, it ensures safe and spillage-free bunkering of aviation fuel, both on- and offshore. Our helicopter and overwing refueling nozzles and couplings are proven to take the strain in tough environments.



G457 helicopter refueling nozzle

The G457 Helicopter Refueling Nozzle was originally developed by Emco Wheaton for military applications. This nozzle is designed to ensure that fuel cannot be accidentally delivered into the engine air intake during hot refueling. Commercial Helicopter operators will appreciate the significant cost advantages in terms of the reduction in turbine cold starts occurring from the ability to safely refuel with rotors turning.

Features and Benefits:

- Proximity (deadman) lever which automatically shuts off fuel delivery on withdrawal of the nozzle spout from the filler neck;
- High Level Shut off by fuel sensor in spout, also equipped with anti-froth device;
- Manual override for tank filling to absolute maximum capacity;
- Supplied complete with 100 mesh inlet strainer, dust cap, and grounding wire;
- Black anodised finish for all-weather protection;
- Tested for temperatures as low as -30°C;
- Fuel resistant Buna-N splashguard;
- High level shut-off maintained down to flow rate of 37.8 litres/min (10 US gal/ min);
- Flow control mechanism is capable of handling pressures up to 110 psi;
- Swivel integrated into nozzle;
- NATO specification

Available Configurations:

- Curved or straight spout (other spout configurations available)
- Female ISO or female NPT inlet
- Varying ground cable lengths available



Repair kit program

Emco wheaton has developed a series of repair kits suitable for the field repair of the Hot Refuelling Nozzle for Helicopters. If a nozzle has a leaky seal or 'O' Ring, or a part worn, the installation of a complete repair kit in that area of concern will give the user far better value for his money, rather than just replacing one or two parts. The installation of the kit renders a wear zone on the nozzle completely rebuilt, and will consequently give longer service life. These kits are available off the shelf, and come complete with instructions, diagram and everything needed to make the repair. The part number is prominently displayed for easy stock identification.

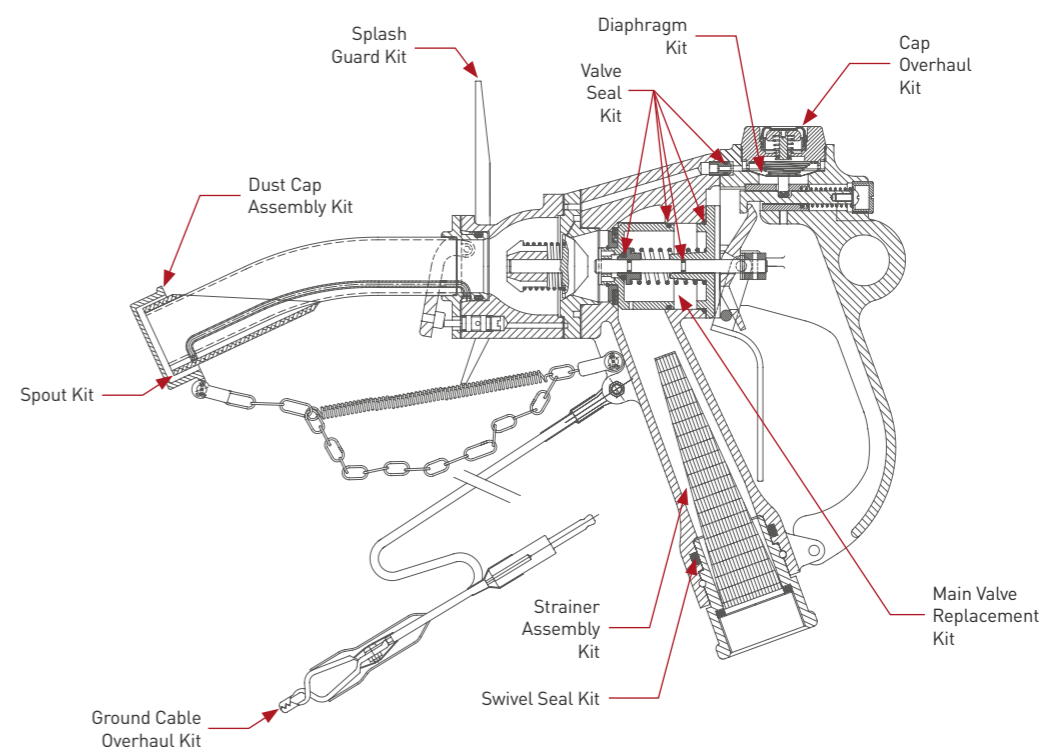

Flow rate

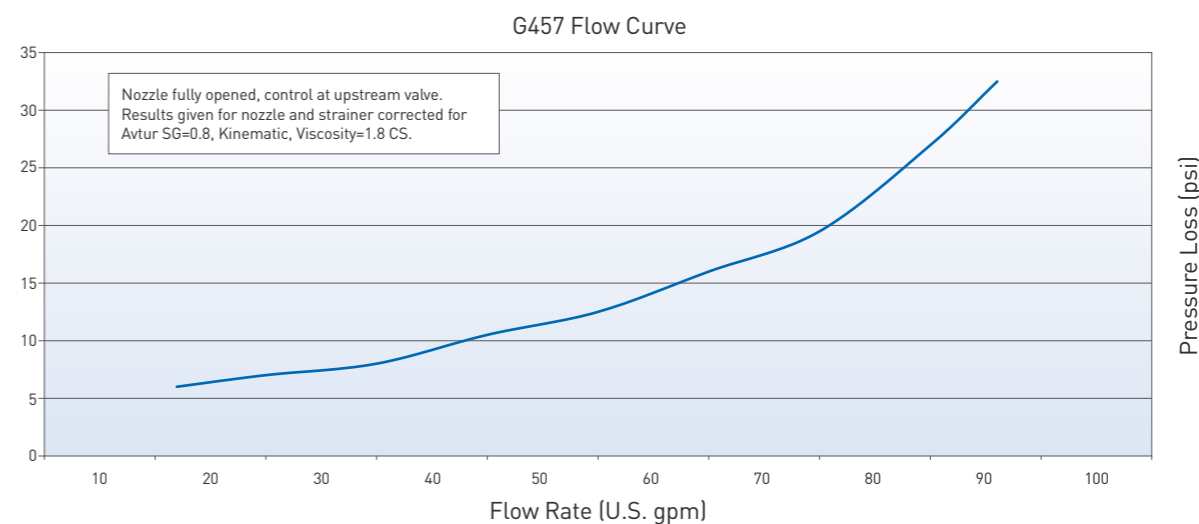

G180 overwing nozzle features and benefits

The G180 Nozzle is built on a modified G457 chassis. The G457 has been the preferred nozzle of many military organizations around the world for many years. In opting for the G180, you will benefit from the experience we have gained in the field with this proven design.

Speed Spout™
quick change mechanism allows spouts to be installed and removed with one hand. (optional)

Elastomeric Ring
prevents nozzle from damaging aircraft during fueling.

Factory Tested and Traceable
each nozzle is flow and leak tested at the factory and assigned a serial number. Serial number can be traced to test date and results achieved. Serial number and manufacture date are engraved on the nozzle.

The Nozzle
is free of yellow metal and plastic components.

Stowage Device
holds grounding plug in place until needed.

Metering Ability
the valve design makes it easy to control flow. Allows the fueler to smoothly increase and decrease flow without line shock or recoil. Makes fueling process more efficient and less strenuous for the fueler.

Bumper Pads
on contact points help prevent accidental scratching of aircraft.

100-Mesh Stainless Steel Strainer
—easily accessible for routine inspection.

Body and Handle Guard
Aluminum construction — anodized black as per MIL-A-8625F Type II Class 2.

Integrated Swivel

- Anodized aluminum construction designed specifically to maintain electrical continuity between swivel and hose.
- Rotates on Ballbearing surface.
- Double O-Ring sealing system.
- Available with check valve if desired.
- Available with ISO 228, NPT inlet.

Spouts

- 3 quick change spout configurations 1", 1.5" and flared are available and interchangeable)
- 3 threaded spout configurations are available and interchangeable.



Stainless Steel Spout Restraint
is wider than fuel port while allowing fueler to see into tank.



Dust Cap

Non-metallic and fuel resistant— will not damage aircraft. (optional)



Grounding Cable

- 2 options available (both include alligator clip and grounding plug).
- Nozzle available without grounding cable if desired.

Outline Dimensions

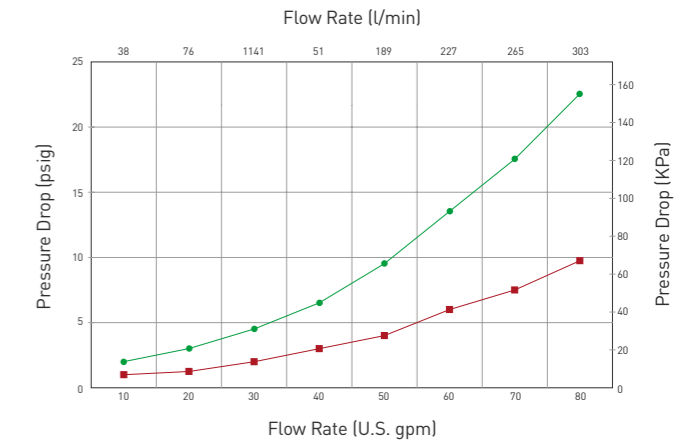
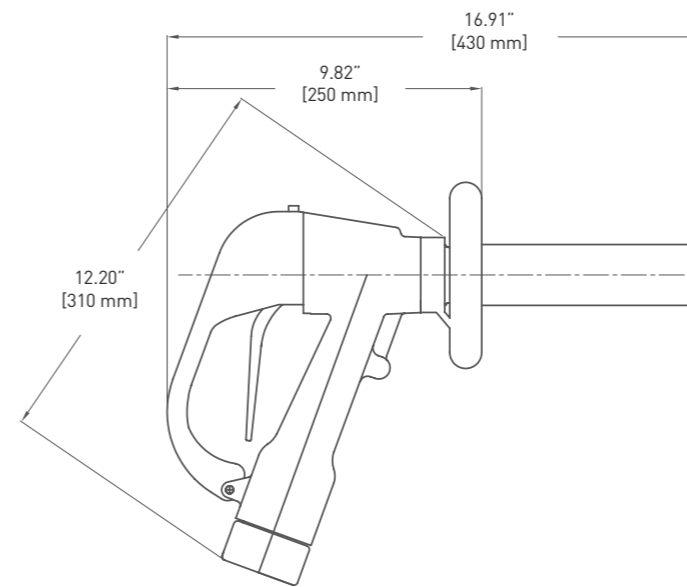

● 1" Spout w/1.5" NPT inlet ■ 1.5" Spout w/1.5" NPT inlet

- Weight of nozzle with 1.5" straight spout, inlet check valve and bumper ring = 6.95 lbs (3.15 kg)
- Seals are compatible with all jet and aviation fuels.

Repair Kit Program

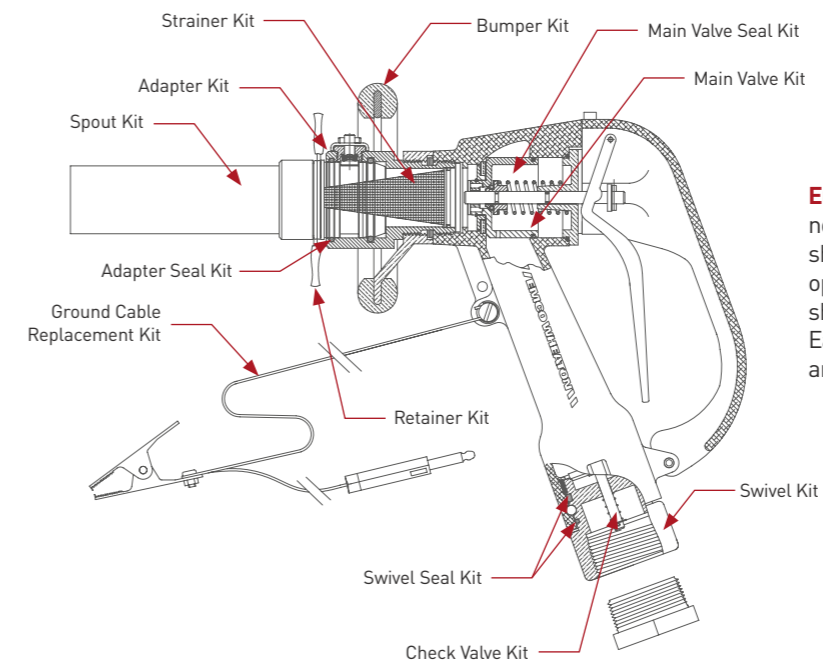

Emco Wheaton is a firm believer in repair kits. Each nozzle — which is shipped in a box with a large label showing model number and serial number — contains operating instructions and a diagram similar to the one shown depicting the repair kits available for that nozzle. Each kit includes instruction sheet and all components and consumables needed to repair the specific wear zone.

How To Order

The G180 is available with exactly the features that you desire. To configure your nozzle, simply select one item from each of the option categories to form the part number. For example, a nozzle with 1.5" Flared spout and bumper ring, 1.5" NPT inlet without check valve, Standard Grounding cable and Dust Cap, and Black Handle Guard — would be part number G180-LBTB.



Automatic Hot Refueling Nozzles - G457

The G457 Automatic Helicopter Refueling Nozzle was originally developed for military applications. This nozzle is designed to ensure that fuel cannot be accidentally delivered into the engine air intake during hot refueling (fueling with rotors turning).



Overwing Fueling Nozzles with Speed Spout - G180

We developed the G180 Overwing Refueling Nozzle for fueling commercial and military airplanes and helicopters. This nozzle is designed to be lightweight, comfortable to operate, and rugged.



Standard Overwing Nozzles - G180

Whether you are fueling military jets in the desert or helicopters on an oil rig, or a training plane at your local FBO, we have the solution to meet your fueling needs! The G180 Overwing Nozzle is configurable with a number of different spout, inlet and accessory options.



Dry-Break Couplers & Adapters

Emco Wheaton DRY-BREAK couplers and DRY-BREAK adapters are designed for total safety. Fluid cannot flow until the Emco Wheaton coupler has been locked into position on an Emco Wheaton Adapter and the valve opened. The coupler can only be disconnected from the adapter when the valve has been closed. Since product loss is thereby eliminated, possible hazards associated with leakage at disconnect are no longer a concern.



API Coupler - J0451

Quality and perfection always drive new standards within Emco Wheaton and this includes our API-coupler range that is used by petro-chemical companies worldwide. The J0451 API Coupler has been the industry standard for over 30 years. It has recently been re-engineered to set a new, higher standard in API Couplings.



API Coupler - J0452

New product development, ongoing product improvement and the flexibility to adapt to customer's individual requirements ensure that our API couplers remain at the leading edge of technology. The J0452 range of API couplers is the most advanced coupler range available in the global market today. Our newly launched J0452 has been engineered as a direct replacement to the K2/K2P to be the SNAP ON / SNAP OFF coupler of choice.



Camsec Coupler

Our Camsec Coupler has been the industry standard in France for over 30 years. This coupler has superior sealing technology, with lowest leakage on disconnect in its class. It is maintenance friendly and has a wide range of spare kits available.



Aviation TODO-45 DRY-BREAK®

An ISO 45 standard ground unit from TODO® with associated hose unit. This gives an economical alternative to ISO 45 standard hose couplers for aviation fuel transfers. This coupler is not configured for under-wing refuelling.



TODO-MATIC® DRY-BREAK® Couplers

When customers ask for DRY-BREAK® couplings for their projects, they often refer to the products as „TODO's“. The TODO-MATIC® product range is exactly what they mean. Don't settle for any less than a real TODO. The TODO-MATIC® DRY-BREAK® coupling is designed to handle the most demanding applications, from potable water to hydrochloric acid, the TODO-MATIC® coupling has consistently provided customers around the world with a reliable means of transferring their valuable or dangerous fluids and gases.

Your Distributor For This Product:



Ali Yaqoob Trading Co. L.L.C

Fueling Excellence Since 1986



P.O. Box 11682, Dubai, U.A.E.
Tel: +9714-3330105; +9714-3332091
Fax: +9714-3330104
E-mail: sales@aliyaqoob.com
www.aliyaqoob.com