

How To Order

The G180 is available with exactly the features that you desire. To configure your nozzle, simply select one item from each of the categories below to form the part number. For example, a nozzle with 1.5" Flared spout and bumper ring, 1.5" NPT inlet without check valve, Standard Grounding cable and Dust Cap, and Black Handle Guard — would be part number G180-LBTB.

G180-NNNB

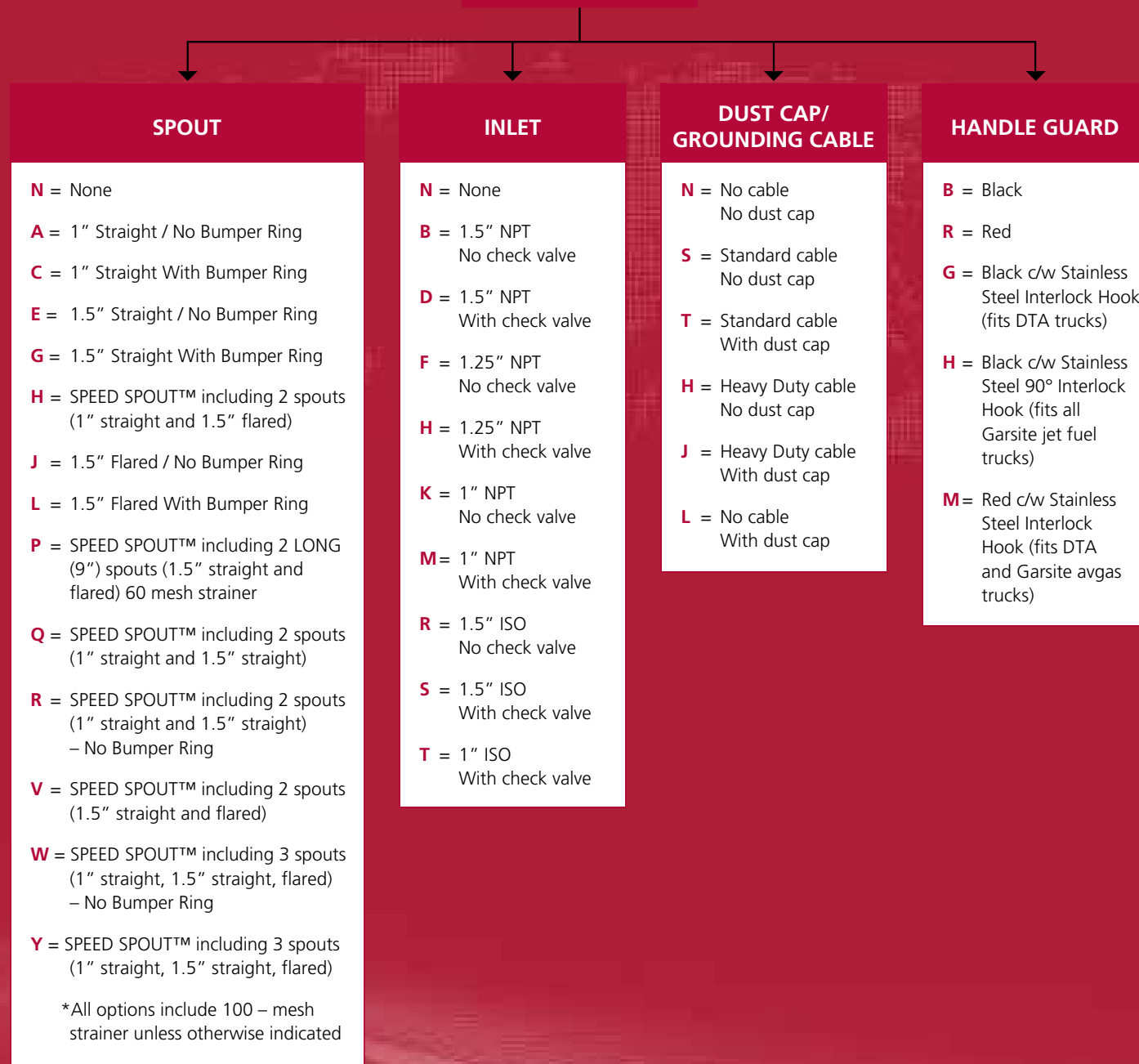

G180 OVERWING NOZZLES



EMCO WHEATON

A Gardner Denver Product

www.emcowheaton.com

assist@emcowheaton.com
Tel: +1 905 829-8619
Fax: +1 905 829-8620

Emco Wheaton Corp.
2390 South Service Road
Oakville, Ontario L6L 5M9
Canada



RAIL

MARINE

G180 OVERWING NOZZLE FEATURES AND BENEFITS

Spouts

- 3 quick change spout configurations (1", 1.5" and flared are available and interchangeable).
- 3 threaded spout configurations are available and interchangeable.



Stainless Steel Spout Restraint

is wider than fuel port while allowing fueler to see into tank.

SPEED SPOUT™

quick change mechanism allows spouts to be installed and removed with one hand. (optional)

Elastomeric Ring

prevents nozzle from damaging aircraft during fueling.

Factory Tested and Traceable

Each nozzle is flow and leak tested at the factory and assigned a serial number. Serial number can be traced to test date and results achieved. Serial number and manufacture date are engraved on the nozzle.

The Nozzle

is free of yellow metal and plastic components.

Stowage Device

holds grounding plug in place until needed.

100-Mesh Stainless Steel Strainer

–easily accessible for routine inspection.



Grounding Cable

- 2 options available (both include alligator clip and grounding plug).
- Nozzle available without grounding cable if desired.



Dust Cap

Non-metallic and fuel resistant – will not damage aircraft. (optional)

Body and Handle Guard

Aluminum construction – anodized black as per MIL-A-8625F Type II Class 2.

Bumper Pads

on contact points help prevent accidental scratching of aircraft.

Metering Ability

The valve design makes it easy to control flow. Allows the fueler to smoothly increase and decrease flow without line shock or recoil. Makes fueling process more efficient and less strenuous for the fueler.

Integrated Swivel

- Anodized aluminum construction designed specifically to maintain electrical continuity between swivel and hose.
- Rotates on Ballbearing surface.
- Double O-Ring sealing system.
- Available with check valve if desired.
- Available with ISO 228, NPT inlet.

PROVEN DESIGN

The G180 Nozzle is built on a modified G457 chassis. The G457 has been the preferred nozzle of many military organizations around the world for many years. In opting for the G180, you will benefit from the experience we have gained in the field with this proven design.

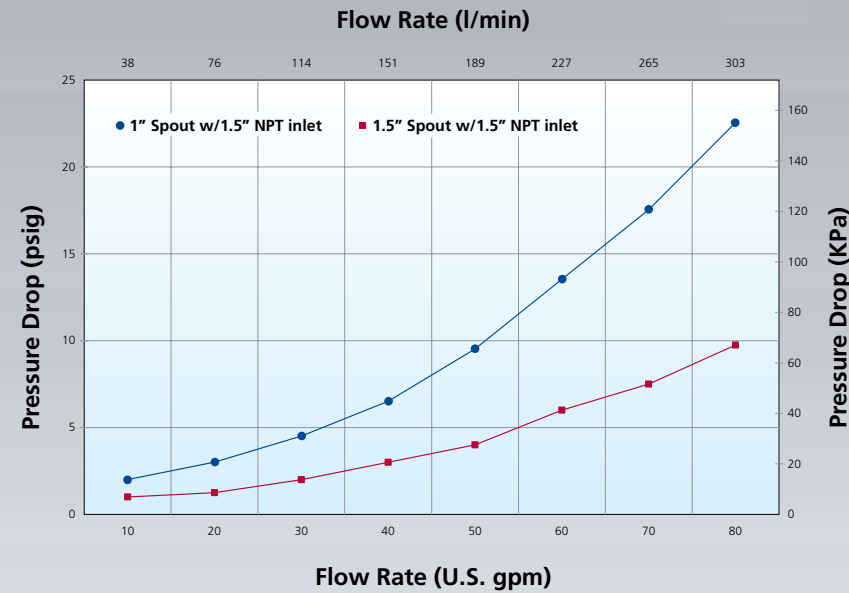

- Weight of nozzle with 1.5" straight spout, inlet check valve and bumper ring = 6.95 lbs (3.15 kg)
- Seals are compatible with all jet and aviation fuels.

Outline Dimensions

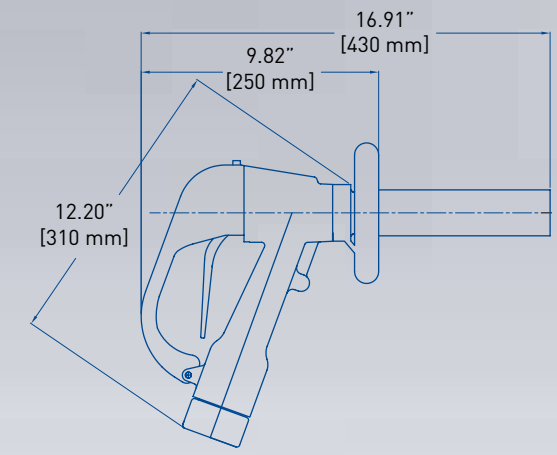

Repair Kit Program

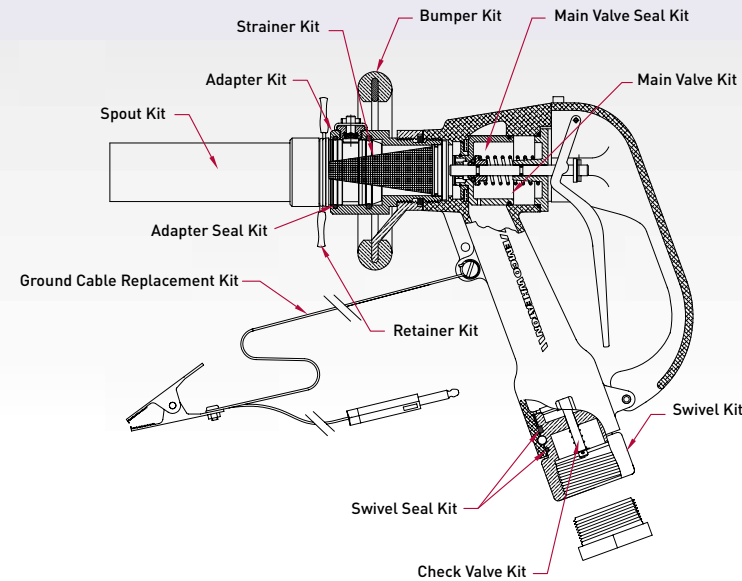

EMCO WHEATON is a firm believer in repair kits. Each nozzle – which is shipped in a box with a large label showing model number and serial number – contains operating instructions and a diagram similar to the one shown depicting the repair kits available for that nozzle. Each kit includes instruction sheet and all components and consumables needed to repair the specific wear zone.